



3907

Parts Catalog

GC28-6976-00





3907

Parts Catalog

GC28-6976-00

Note

Before using this information and the product it supports, read the information in “Safety” on page v, “Notices,” on page A-1, and *IBM Systems Environmental Notices and User Guide, Z125-5823*.

This edition, GC28-6976-00, applies to the 3907 server.

Figures included in this document illustrate concepts and are not necessarily accurate in content, appearance or specific behavior.

There may be a newer version of this document in a PDF file available on Resource Link. Go to <http://www.ibm.com/servers/resourceLink> and click Library on the navigation bar.

© Copyright IBM Corporation 2018.

US Government Users Restricted Rights – Use, duplication or disclosure restricted by GSA ADP Schedule Contract with IBM Corp.

Contents

Safety	v
Safety notices	v
World trade safety information	v
Danger notices	v
Laser safety information	v
Laser compliance	v
About this publication	vii
How to send your comments	vii
Accessibility	vii
Accessibility features	vii
Keyboard navigation	vii
Consult assistive technologies	viii
IBM and accessibility	viii
Chapter 1. FRU list	1-1
1.	1-1
2.	1-1
3.	1-1
Chapter 2. Catalog section	2-1
Assembly 1: A frame assembly, side covers, mounting hardware	2-1
Assembly 2: A frame assembly, hinges, door latch, ESD clip bracket	2-2

Assembly 3: A frame, front and rear covers	2-3
Assembly 4: Power Display Units (PDUs)	2-4
Assembly 5: A frame tie down, non-raised floor	2-5
Assembly 6: A frame tie down, raised floor	2-6
Assembly 7: PCIe+ I/O drawer assembly	2-7
Assembly 8: PCIe+ filler plates, rails	2-8
Assembly 9: CPC drawer assembly	2-9
Assembly 10: CPC rails	2-10
Assembly 11: Top exit I/O mounting	2-11
Assembly 12: Tail gate filler mounting	2-12
Assembly 13: Raised floor tailgate mounting	2-13
Assembly 14: Tip plate	2-14
Assembly 15: Height reduction	2-15
Assembly 16: Frame stiffener, front and rear	2-16
Assembly 17: Keyboard/monitor drawer assembly	2-17
Assembly 18: Support Elements	2-18

Chapter 3. Cable guide	3-1
Assembly 19: Power cords	3-1
Assembly 20: Cable assemblies.	3-1

Appendix. Notices	A-1
Trademarks	A-2
Class A Notices	A-2

Safety

Safety notices

Safety notices may be printed throughout this guide. **DANGER** notices warn you of conditions or procedures that can result in death or severe personal injury. **CAUTION** notices warn you of conditions or procedures that can cause personal injury that is neither lethal nor extremely hazardous. **Attention** notices warn you of conditions or procedures that can cause damage to machines, equipment, or programs.

World trade safety information

Several countries require the safety information contained in product publications to be presented in their translation. If this requirement applies to your country, a safety information booklet is included in the publications package shipped with the product. The booklet contains the translated safety information with references to the US English source. Before using a US English publication to install, operate, or service this product, you must first become familiar with the related safety information in the *Systems Safety Notices*, G229-9054. You should also refer to the booklet any time you do not clearly understand any safety information in the US English publications.

Danger notices

There are no **Danger** notices in this guide.

Laser safety information

All IBM Z[®] (Z) and IBM LinuxONE[™] (LinuxONE) models can use I/O cards such as FICON[®], Open Systems Adapter (OSA), InterSystem Channel-3 (ISC-3), zHyperLink Express, or other I/O features which are fiber optic based and utilize lasers (short wavelength or long wavelength lasers).

Laser compliance

All lasers are certified in the US to conform to the requirements of DHHS 21 CFR Subchapter J for Class 1 or Class 1M laser products. Outside the US, they are certified to be in compliance with IEC 60825 as a Class 1 or Class 1M laser product. Consult the label on each part for laser certification numbers and approval information.

CAUTION: Data processing environments can contain equipment transmitting on system links with laser modules that operate at greater than Class 1 power levels. For this reason, never look into the end of an optical fiber cable or open receptacle. (C027)

CAUTION: This product contains a Class 1M laser. Do not view directly with optical instruments. (C028)

About this publication

This Parts Catalog contains listings and illustrations of replaceable assemblies and detailed parts.

IBM® has prepared this manual for the use of IBM customer service representatives in the installation, maintenance, and repair of the specific machines indicated. IBM makes no representations that it is suitable for any other purpose.

Note that references to the 3907 are applicable to IBM z14™ Model ZR1 and IBM LinuxONE Rockhopper II processors.

How to send your comments

Your feedback is important in helping to provide the most accurate and high-quality information. Send your comments by using Resource Link® at <http://www.ibm.com/servers/resourcelink>. Click **Feedback** on the navigation bar on the left. You can also send an email to reslink@us.ibm.com. Be sure to include the name of the book, the form number of the book, the version of the book, if applicable, and the specific location of the text you are commenting on (for example, a page number, table number, or a heading).

Accessibility

Accessible publications for this product are offered in EPUB format and can be downloaded from Resource Link at <http://www.ibm.com/servers/resourcelink>.

If you experience any difficulty with the accessibility of any IBM Z® information, go to Resource Link at <http://www.ibm.com/servers/resourcelink> and click **Feedback** from the navigation bar on the left. In the **Comments** input area, state your question or comment, the publication title and number, choose **General comment** as the category and click **Submit**. You can also send an email to reslink@us.ibm.com providing the same information.

When you send information to IBM, you grant IBM a nonexclusive right to use or distribute the information in any way it believes appropriate without incurring any obligation to you.

Accessibility features

The following list includes the major accessibility features in IBM Z documentation, and on the Hardware Management Console and Support Element console:

- Keyboard-only operation
- Interfaces that are commonly used by screen readers
- Customizable display attributes such as color, contrast, and font size
- Communication of information independent of color
- Interfaces commonly used by screen magnifiers
- Interfaces that are free of flashing lights that could induce seizures due to photo-sensitivity.

Keyboard navigation

This product uses standard Microsoft Windows navigation keys.

Consult assistive technologies

Assistive technology products such as screen readers function with our publications, the Hardware Management Console, and Support Element console. Consult the product information for the specific assistive technology product that is used to access the EPUB format publication or console.

IBM and accessibility

See <http://www.ibm.com/able> for more information about the commitment that IBM has to accessibility.

Chapter 1. FRU list

Use the following procedure to determine the part numbers of the FRUs within a CPC or CPC drawer.

1

Ensure that you are logged on the Support Element in service mode.

On the Support Element workplace window:

1. Click **Tasks Index** on the left-hand navigation pane.
 2. From the tasks index, click **View Hardware Configuration**.
-

2

On the View Hardware Configuration window:

1. Select the part location from the menu.
 2. Select **Details**.
-

3

The Part Details window shows information about the selected part.

When complete:

1. Click **OK**.
2. On the View Hardware Configuration window, click **Cancel**.

Chapter 2. Catalog section

Assembly 1: A frame assembly, side covers, mounting hardware

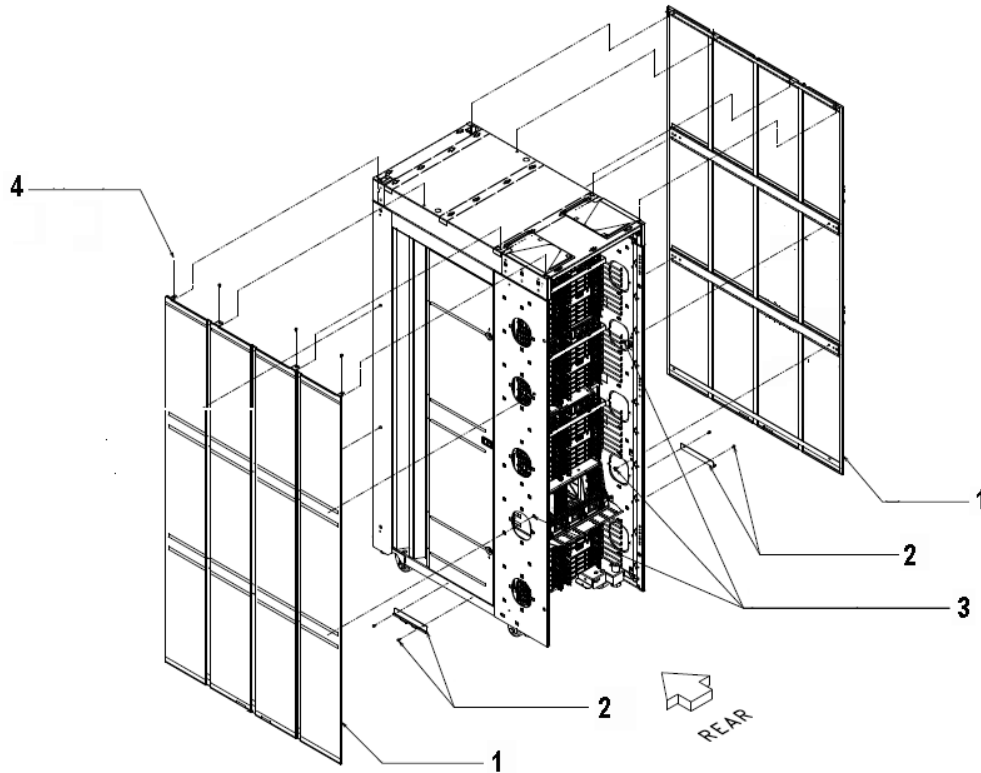

Asm-Index	Part Number	Units	Description
1 - 1	01EL900	2	Side cover
- 2	42V2119	2	J-Bracket Use 46K4282, (2) screw
- 3	01KV618	2	(4) screw with washer
- 4	46K4282	2	(4) Screw

Assembly 2: A frame assembly, hinges, door latch, ESD clip bracket

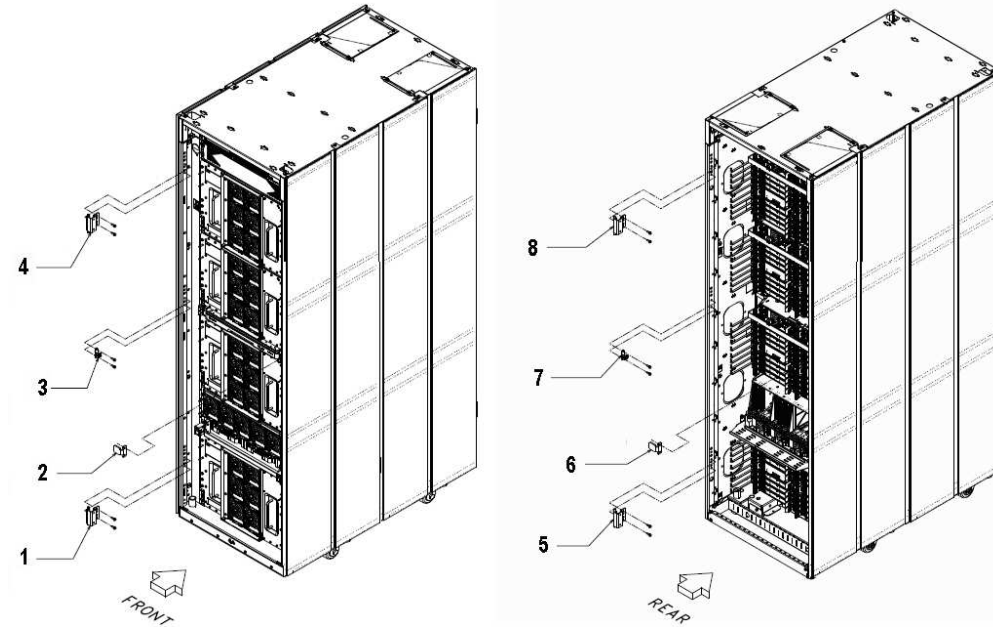

Asm-Index	Part Number	Units	Description
2 - 1	01KU111	1	Hinge, lower Use 46K4284, (2) screw
- 2	01PP000	1	Door latch Use 46K4284, (2) screw
- 3	01VK758	1	ESD clip bracket Use 46K4284, (2) screw
- 4	01KU112	1	Hinge, upper Use 46K4284, (2) screw
- 5	01KU111	1	Hinge, lower Use 46K4284, (2) screw
- 6	01PP000	1	Door latch Use 46K4284, (2) screw
- 7	01VK758	1	ESD clip bracket Use 46K4284, (2) screw
- 8	01KU112	1	Hinge, lower Use 46K4284, (2) screw

Assembly 3: A frame, front and rear covers

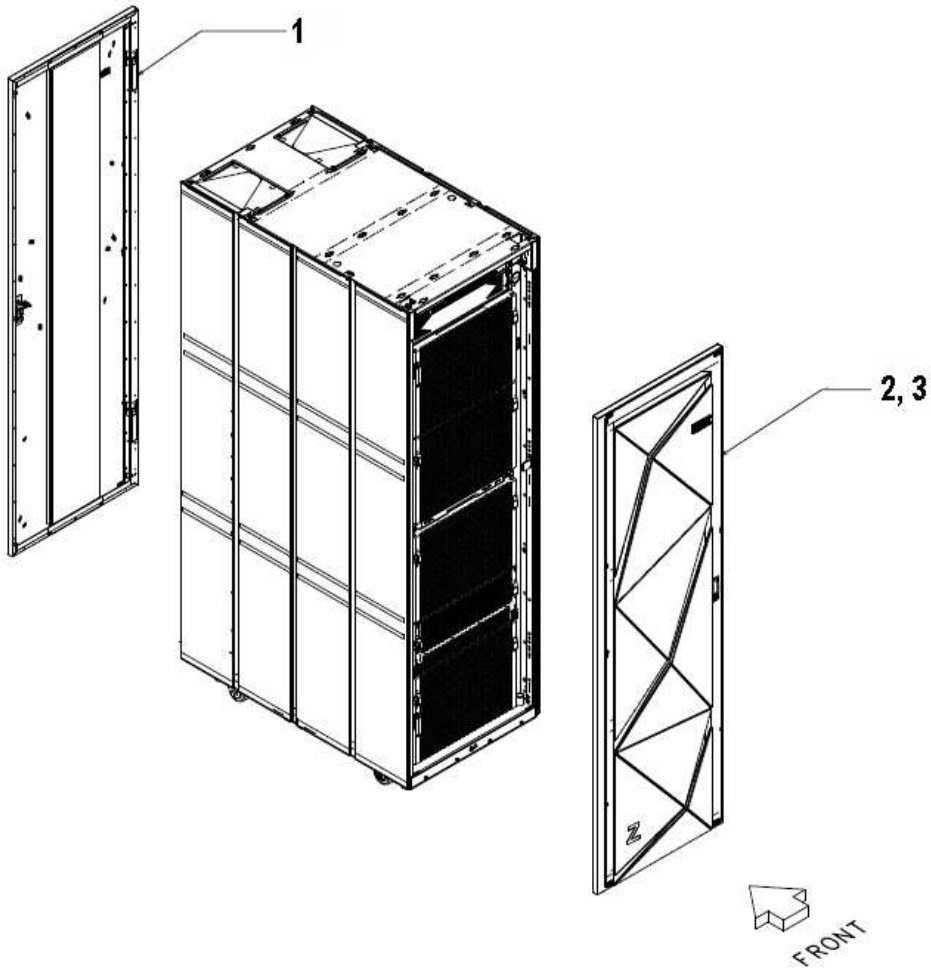

Asm-Index	Part Number	Units	Description
3 - 1	01PP001	1	Cover Assembly, rear
- 2	01KU104	1	Cover assembly, front (IBM)
- 3	01KU124	1	Cover assembly, front (LinuxONE)

Assembly 4: Power Display Units (PDUs)

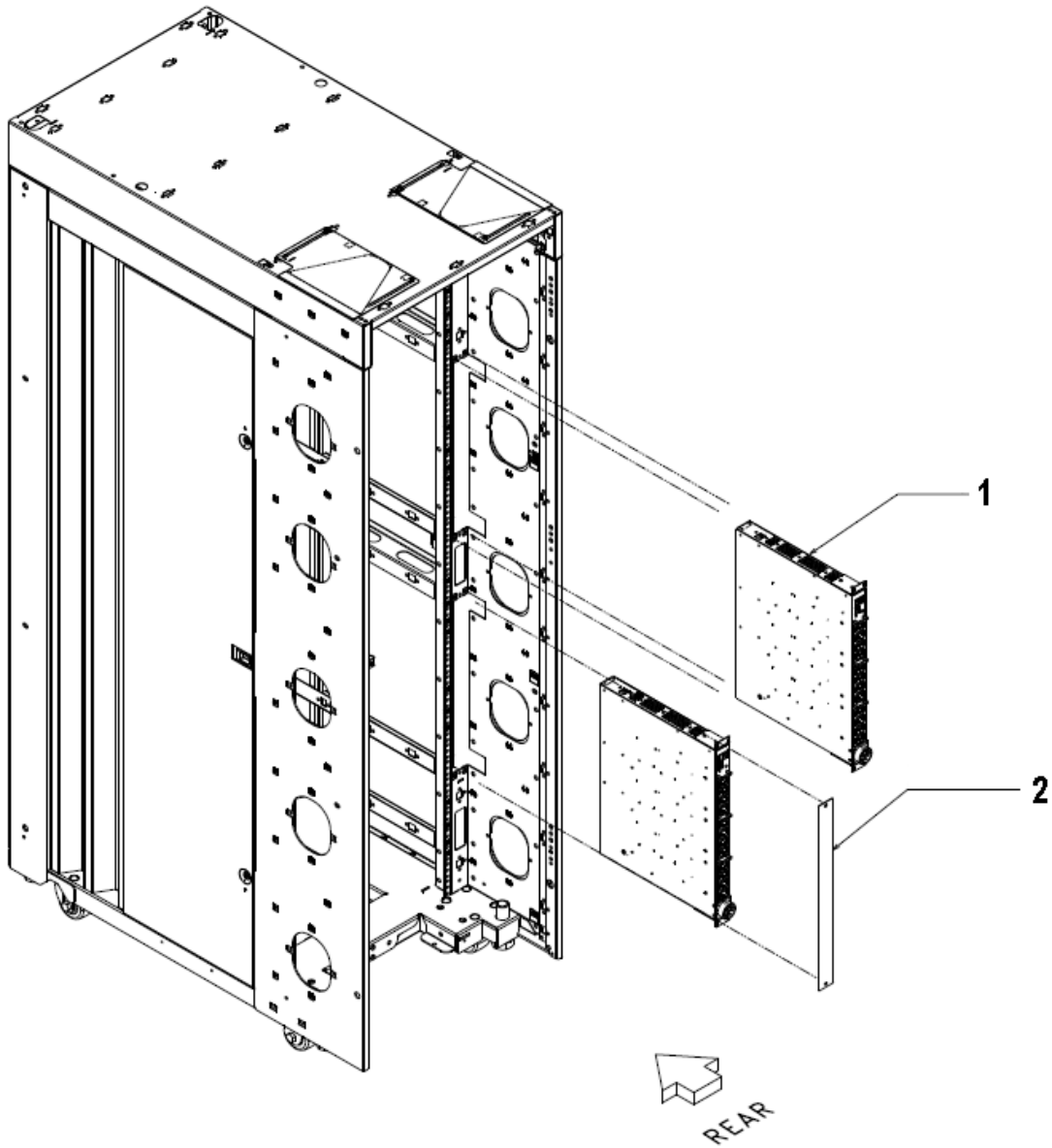

Asm-Index	Part Number	Units	Description
4 - 1		2 or 4	Smart PDU Use 74F1823 (4) nut clip Use 46K4284 (4) screw
- 2	12J4072	AR??	Filler Plate, PDU Use 74F1823 (4) nut clip Use 46K4284 (4) screw

Assembly 5: A frame tie down, non-raised floor

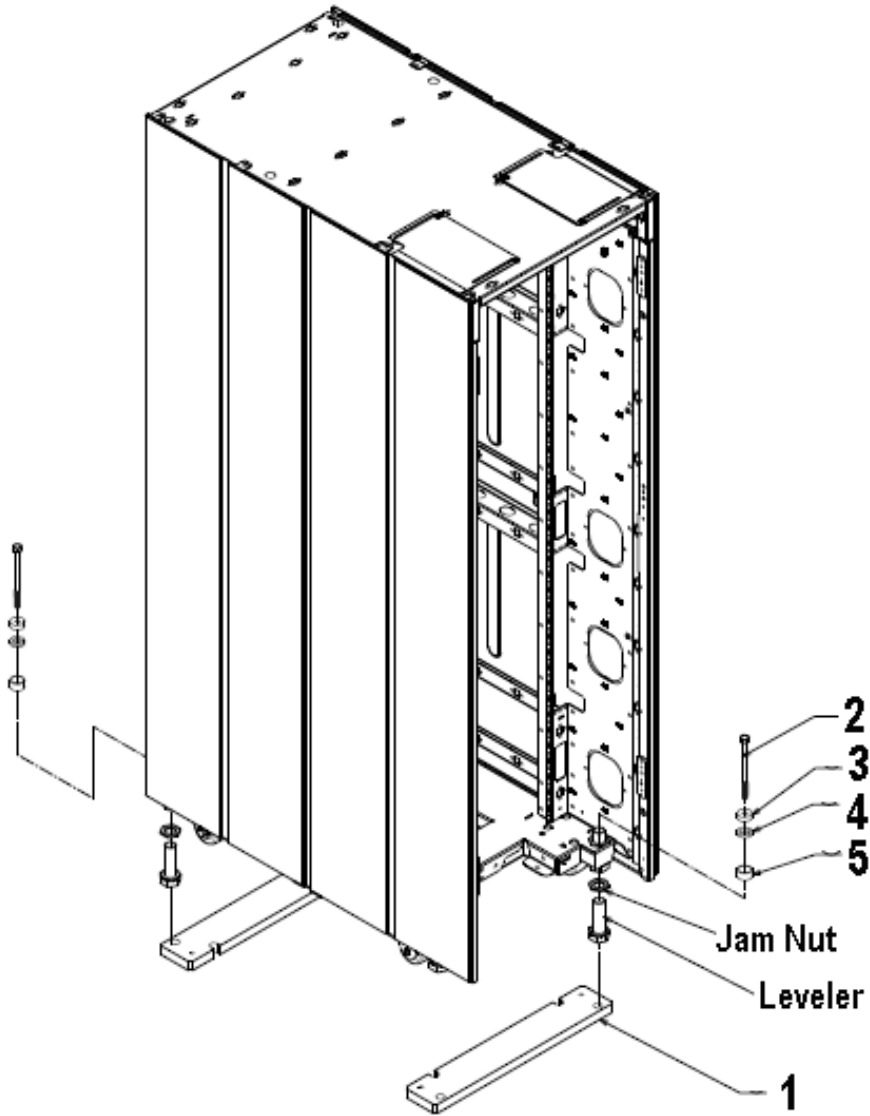

Asm-Index	Part Number	Units	Description
5 - 1	01EL927	2	Lockdown plate
- 2	05N6346	4	Bolt
- 3	45D1614	4	Washer
- 4	12R7497	4	Washer
- 5	12R7498	4	Spacer

Assembly 6: A frame tie down, raised floor

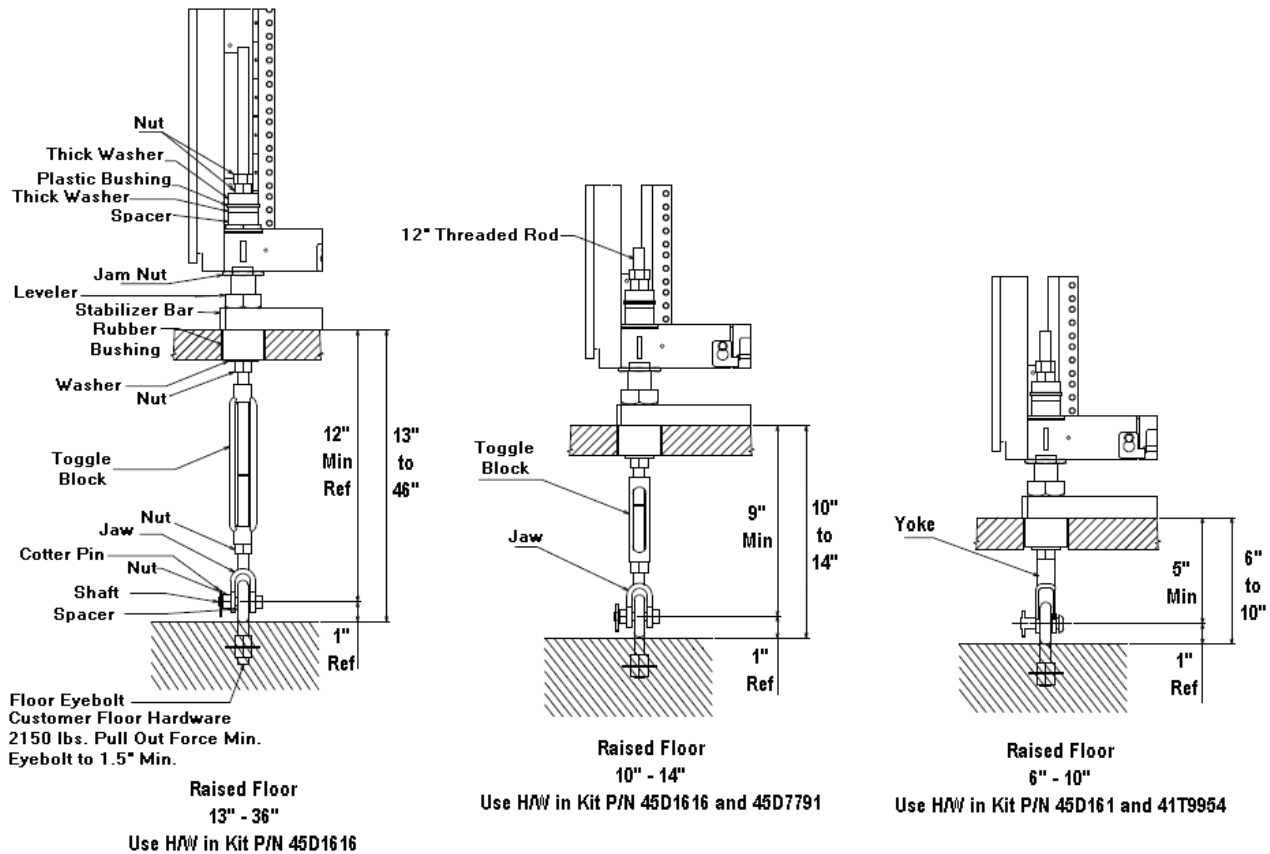

Asm-Index	Part Number	Units	Description
6 - 1	41V1911	1	Wrench
- 2	45W8718	2	Stabilizer Bar
- 3	41T9954	4	Turnbuckle Hardware, 6 inches to 10 inches
- 4	45D7791	4	Turnbuckle Hardware Kit, 10 inches to 14 inches
- 5	45D1616	4	Turnbuckle Assembly, 13 inches to 36 inches
- 6	45D7420	1	Threaded Rod Kit, 36 inches
- 7	74Y0782	4	Threaded Rod, 26 inches

Assembly 7: PCIe+ I/O drawer assembly

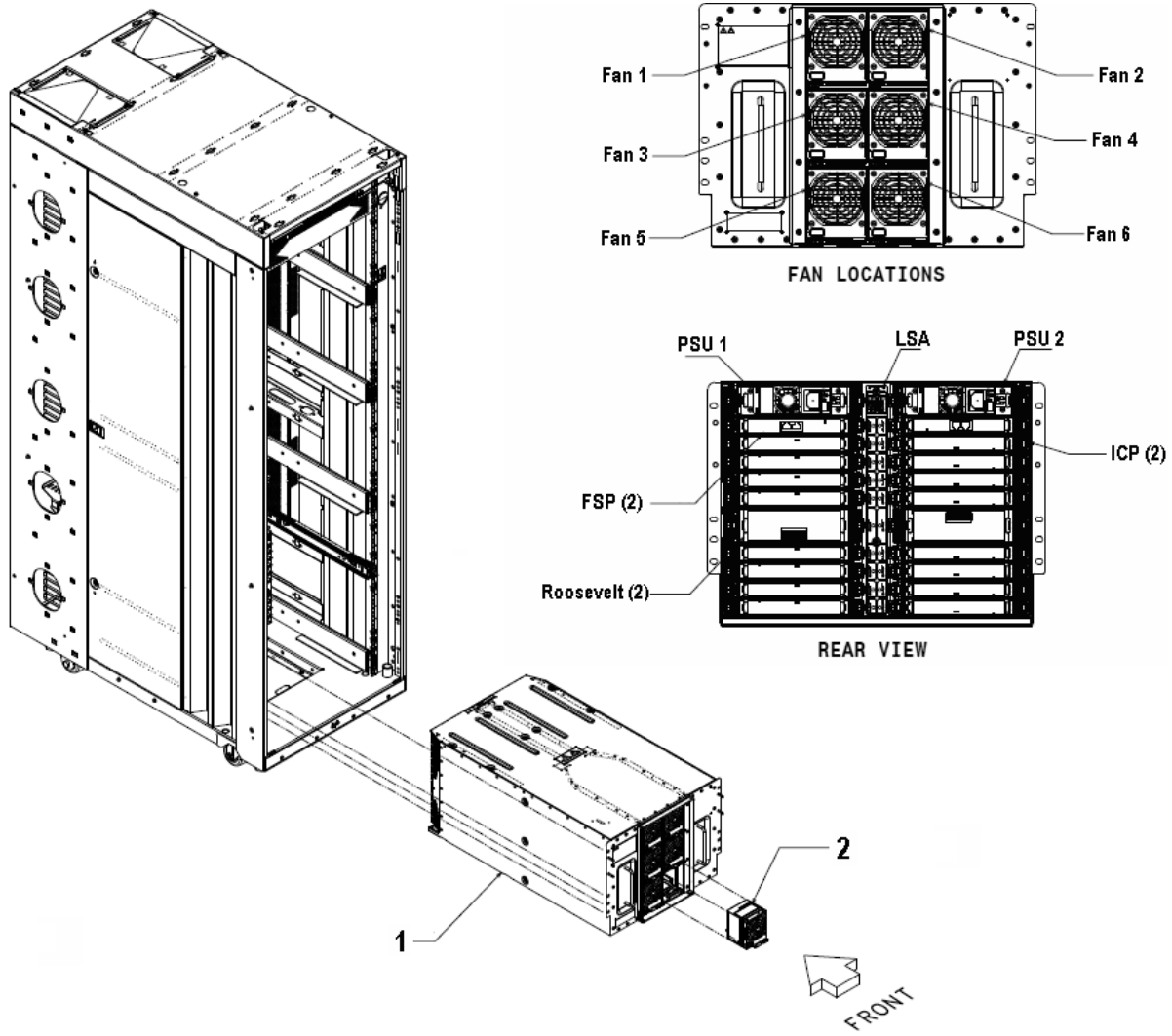

Asm-Index	Part Number	Units	Description
7 - 1		1 - 4	PCIe+ I/O Drawer Use 74F1823, (8) Nut Clip Use 46K4284, (8) Screw
- 2	01AF574	6	Fan, 80mm

Assembly 8: PCIe+ filler plates, rails

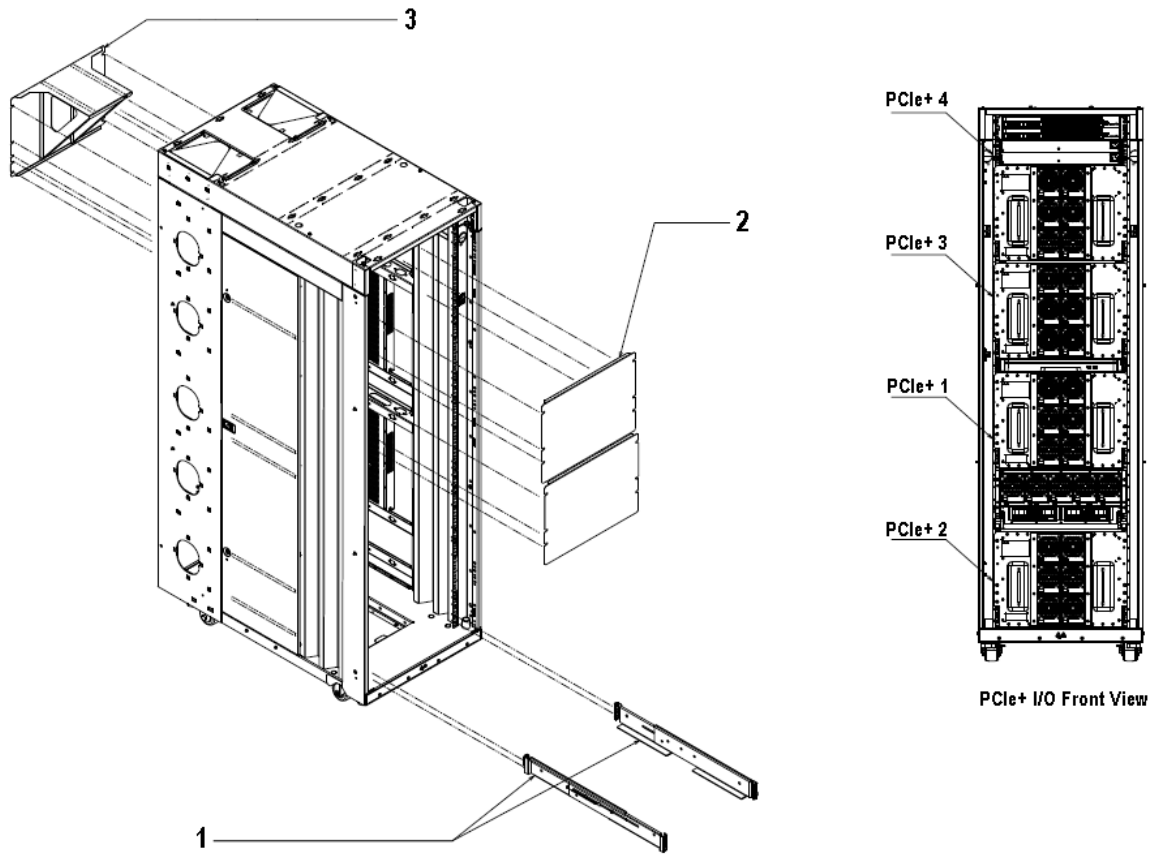

Asm-Index	Part Number	Units	Description
8 - 1	01KL469	2	Rail, Left and Right Use 46K4284, (4) Screw
- 2	01KV722	1 - 4	Filler Plate, Front Use 74F1823, (6) Nut Clip Use 46K4284, (6) Screw
- 3	01KV746	1 - 4	Filler Plate, Rear Use 74F1823, (10) Nut Clip Use 46K4284, (10) Screw

Assembly 9: CPC drawer assembly

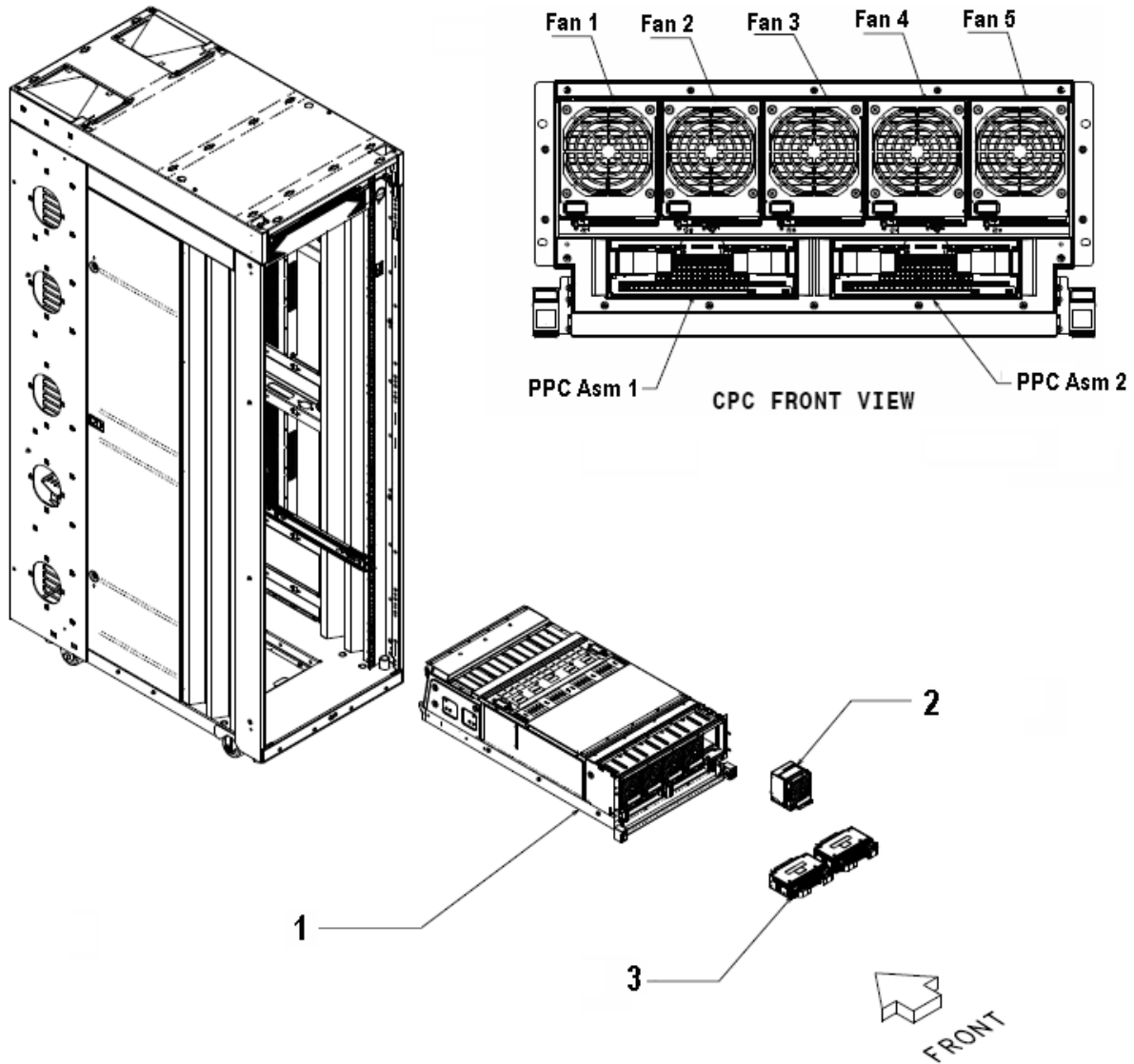

Asm-Index	Part Number	Units	Description
9 - 1		1	CPC Drawer Use 74F1823, (4) Nut Clip Use 46K4284, (4) Screw
- 2	01AF574	5	Fan, 80mm
- 3		2	PPC Assembly

Assembly 10: CPC rails

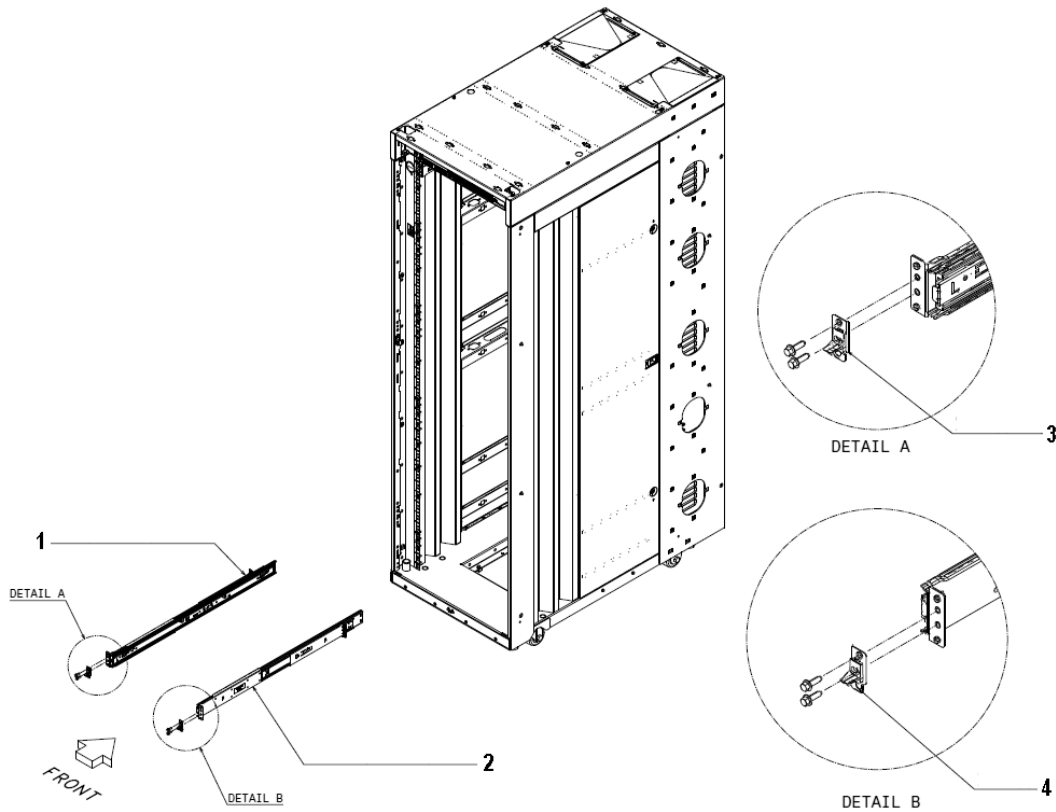

Asm-Index	Part Number	Units	Description
10 - 1	01ML385	1	CPC Rail, Left Use 46K4284, (4) Screw
- 2	01ML386	1	CPC Rail, Right Use 46K4284, (4) Screw
- 3	00RR013	1	Latch Use 46K4284, (2) Screw
- 4	00RR014	1	Latch Use 46K4284, (2) Screw

Assembly 11: Top exit I/O mounting

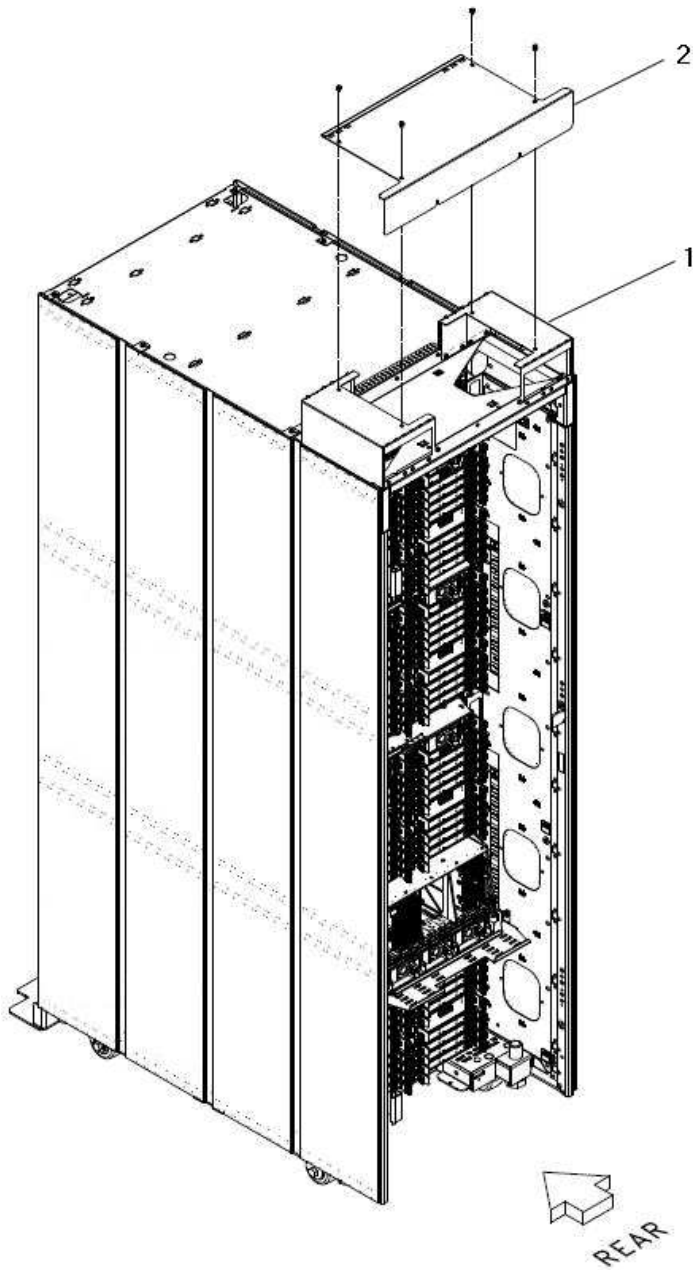

Asm-Index	Part Number	Units	Description
11 - 1	01PP053	1	Top Exit I/O, assembly Use 1624775, (6) Screw
- 2	01PP054	1	Top Cover Use 46K4281, (4) Screw

Assembly 12: Tail gate filler mounting

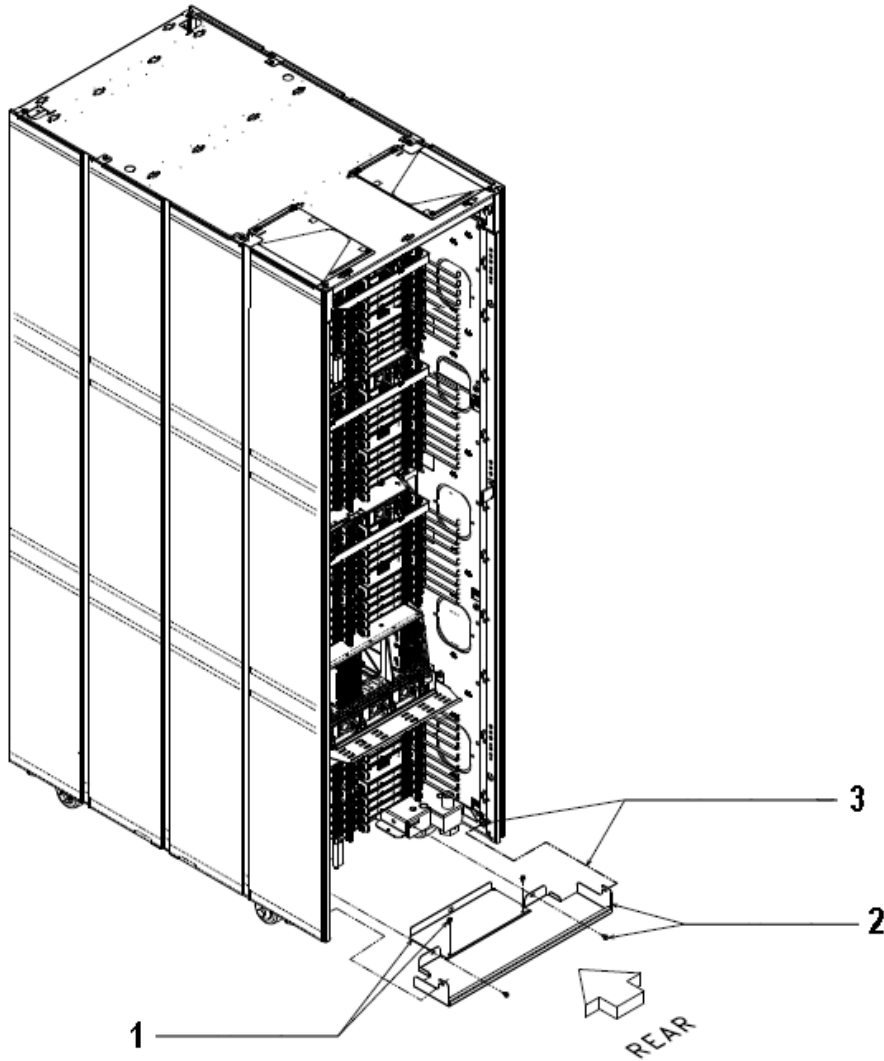

Asm-Index	Part Number	Units	Description
12 - 1	01KU403	1	Tailgate Bracket Use 46K4282, (2) Screw
- 2	01KV541	1	Tailgate Use 46K4282, (2) Screw
- 3	00N8709	2	Nut Clip Use 46K4308, (2) Screw

Assembly 13: Raised floor tailgate mounting

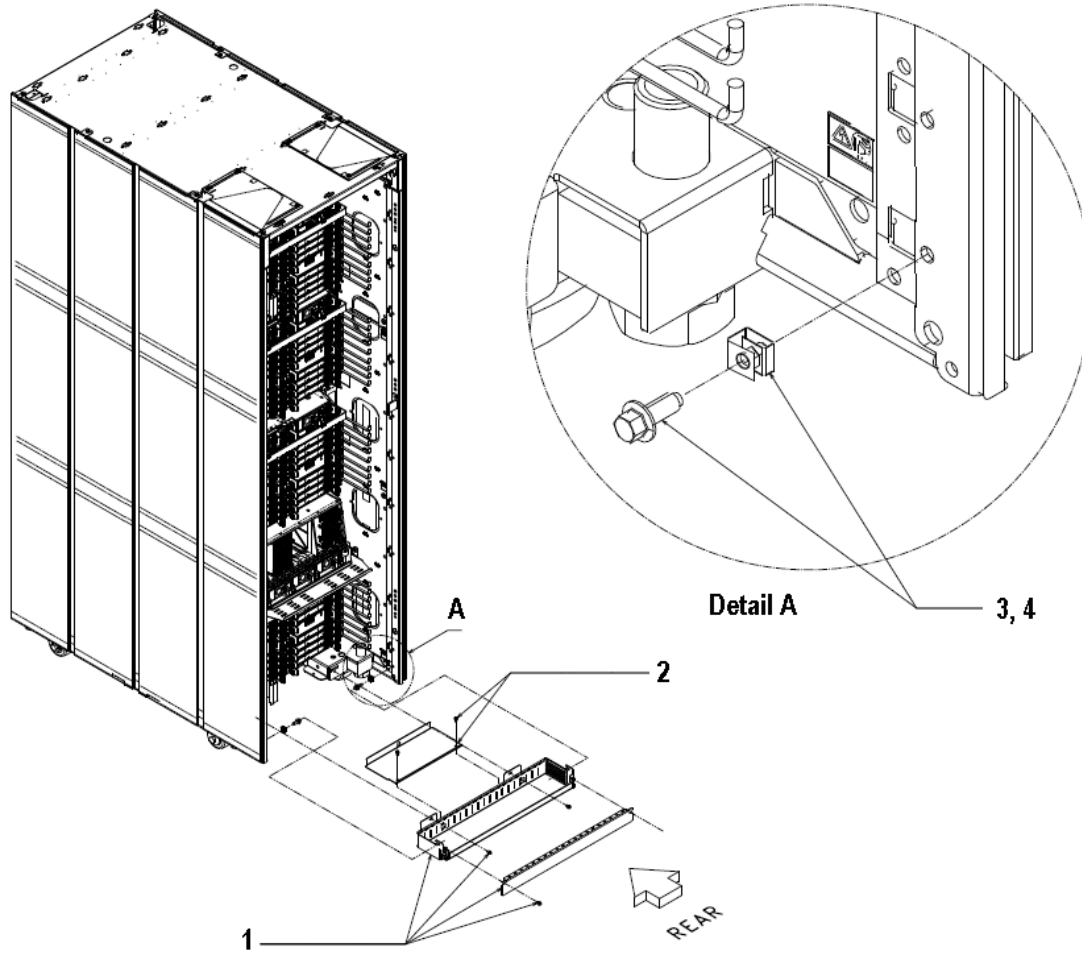

Asm-Index	Part Number	Units	Description
13 - 1	01KU399	1	Tailgate Use 46K4282, (4) screw
- 2	01KU403	1	Bracket, Tailgate Use 46K4282, (2) screw
- 3	00N8709	2	Nut clip
- 4	46K4308	2	Screw

Assembly 14: Tip plate

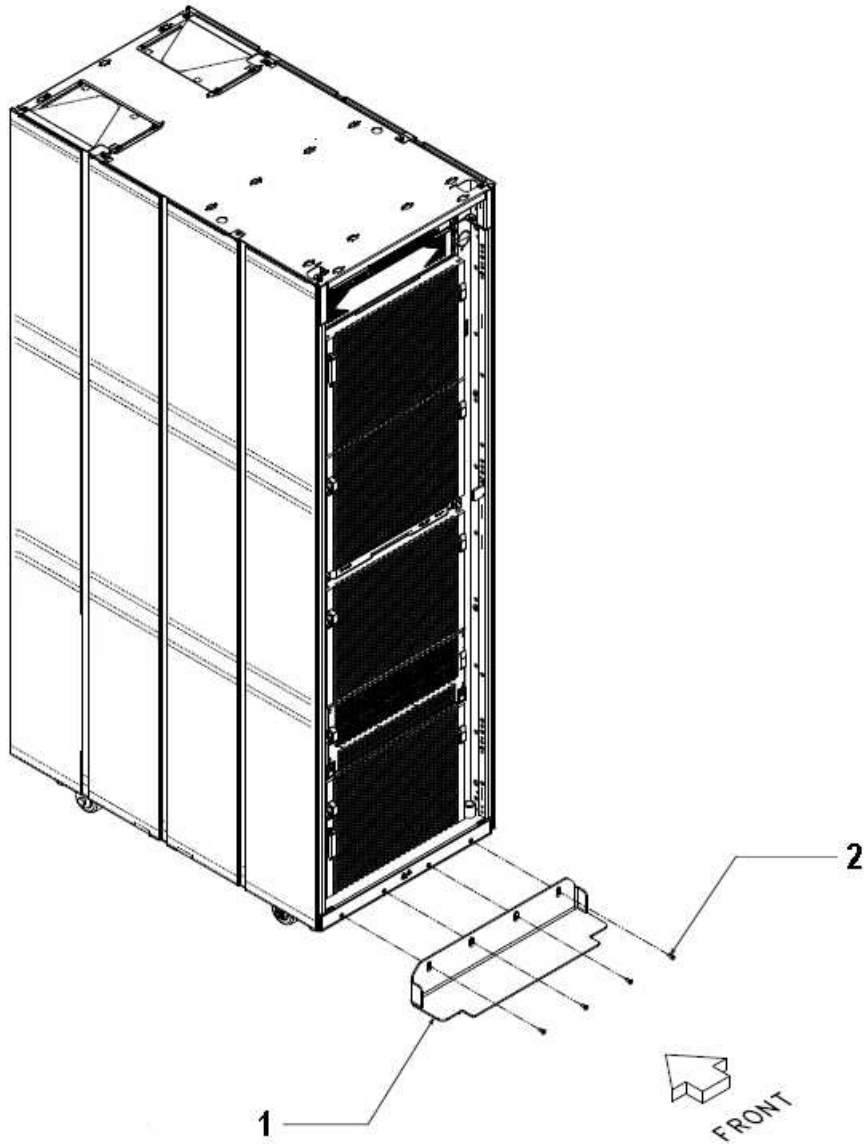

Asm-Index	Part Number	Units	Description
14 - 1	01KL769	1	Tip plate
- 2	74Y1472	4	Screw

Assembly 15: Height reduction

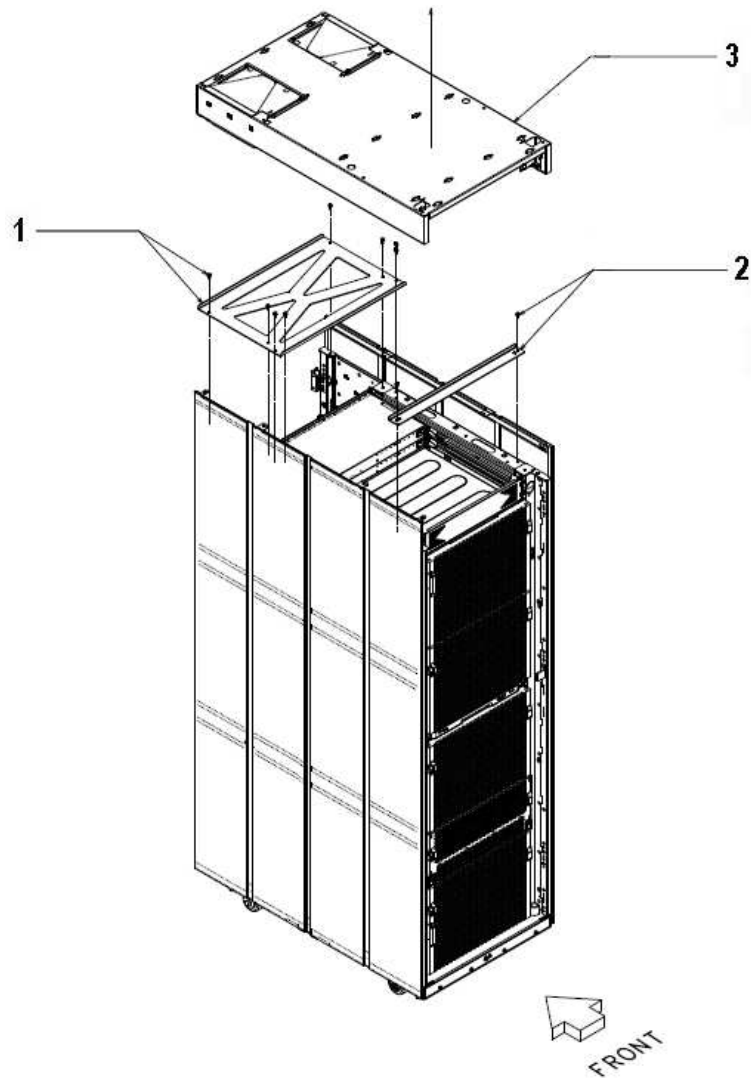

Asm-Index	Part Number	Units	Description
15 - 1	01KV383	1	Height reduction plate Use 46K4308, (8) Screw
- 2	01KV382	1	Height reduction bar Use 46K4308, (2) Screw
- 3		1	Top Hat, Frame Use 46K4308, (18) Screw

Assembly 16: Frame stiffener, front and rear

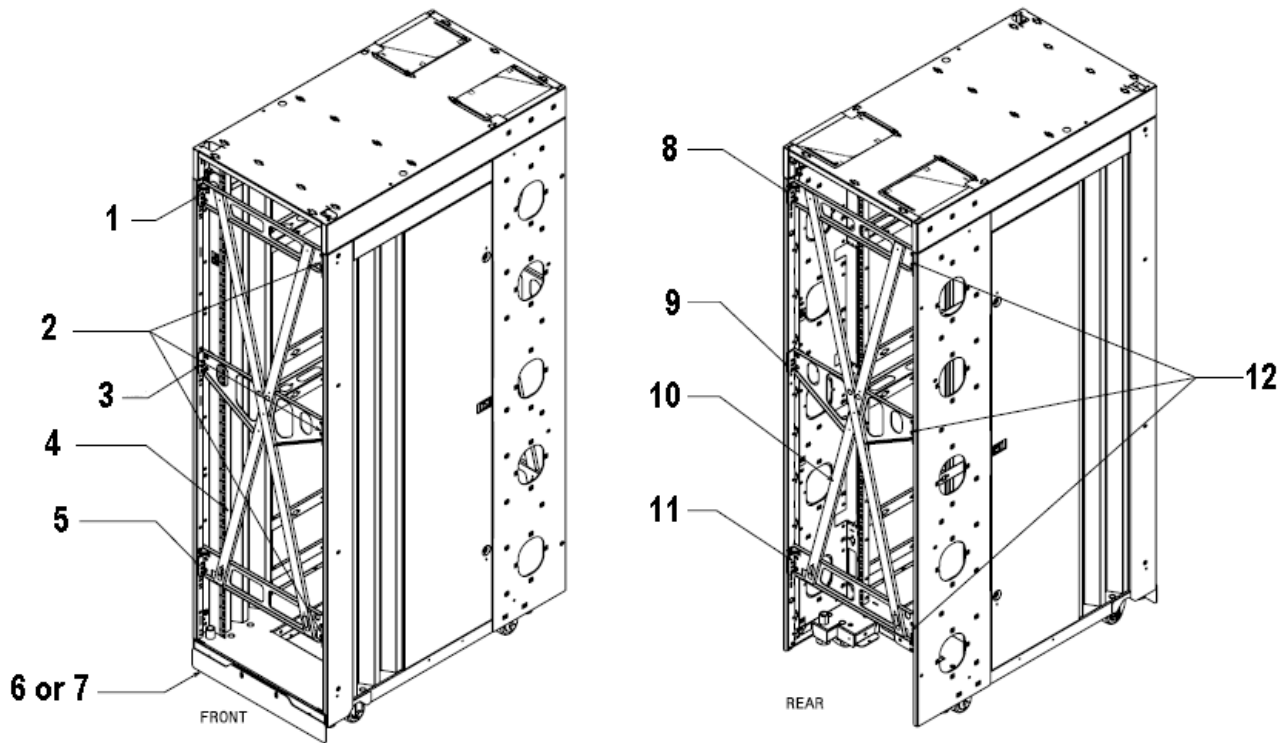

Asm-Index	Part Number	Units	Description
16 - 1	01KV358	1	Hinge bracket, top Use 46K4337, (2) screw
- 2	01EL908	3	Latch bracket, latch side Use 46K4337, (2) screw
- 3	01KU054	1	Latch Bracket, hinge side Use 46K4337, (2) screw
- 4	02EA977	1	X Bracket Use 01KV744, (11) screw
- 5	01KV643	1	Hinge Bracket, bottom Use 46K4337, (2) screw
- 6	01KL479	1	Air Flow Plate, raised floor Use 01KL446, (2) screw
- 7	01PP565	1	Air Flow Plate, non raised floor Use 01KL446, (2) screw
- 8	01KV358	1	Hinge bracket, top Use 46K4337, (2) screw
- 9	01KU054	1	Latch Bracket, hinge side Use 46K4337, (2) screw
- 10	02EA977	1	X Bracket Use 01KV744, (11) screw
- 11	01KV643	1	Hinge Bracket, bottom
- 12	01EL908	3	Latch Bracket, latch side Use 46K4337, (2) screw

Assembly 17: Keyboard/monitor drawer assembly

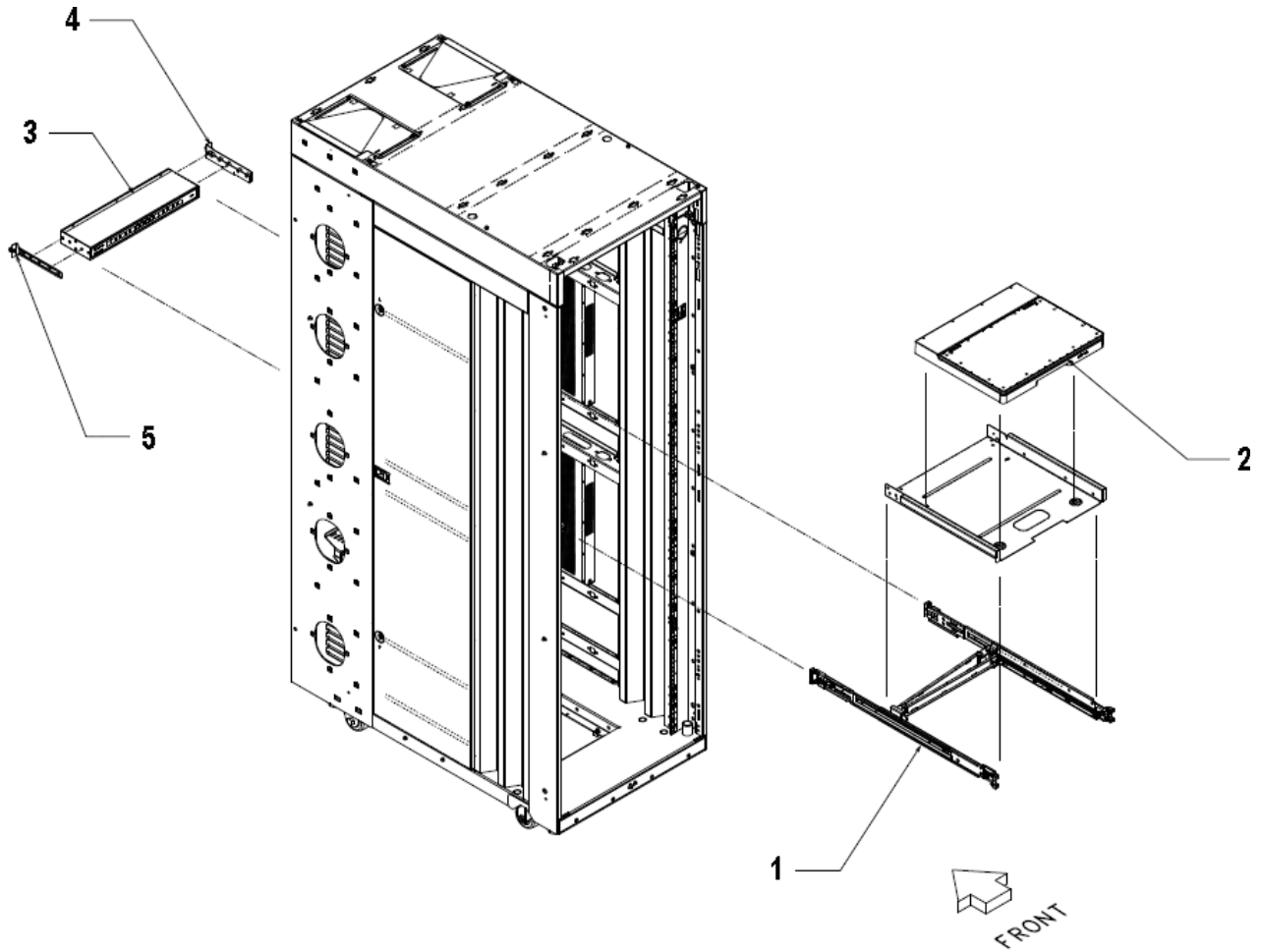

Asm-Index	Part Number	Units	Description
17 - 1	01KU647	1	Monitor Kit Assembly
- 2	01KV992	1	Monitor
- 3	01KV348	1	KVM
- 4		1	Bracket, Left Use (2) Screw Supplied with KVM
- 5		1	Bracket, Right Use (2) Screw Supplied with KVM
NS		1	Keyboard

Assembly 18: Support Elements

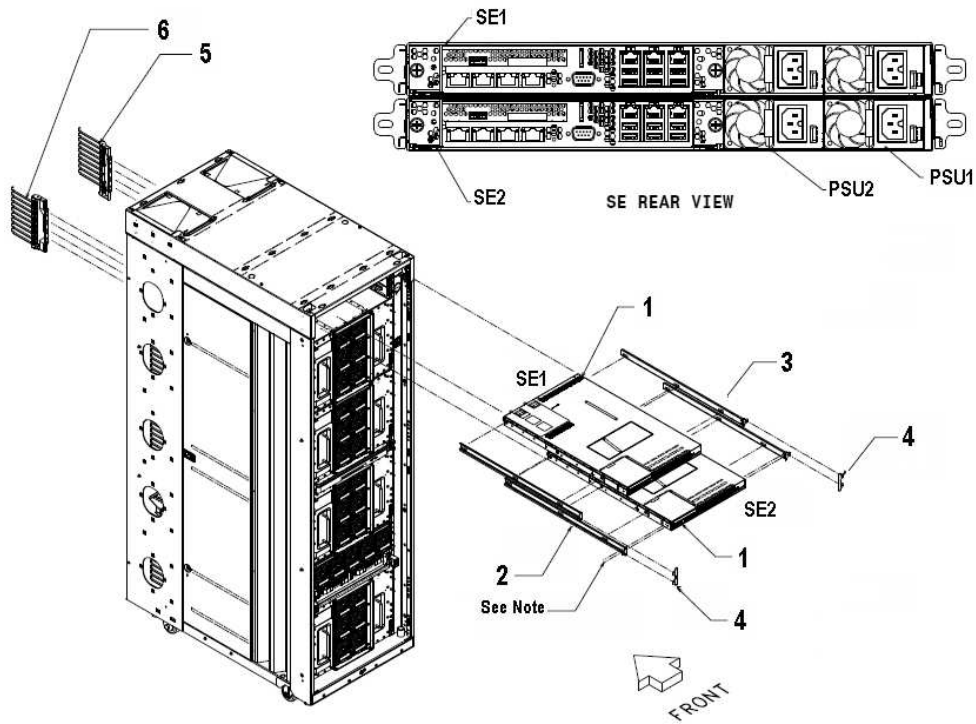

Asm-Index	Part Number	Units	Description
18 - 1		2	Support Element Server, Front, A Frame Use 46K4284 (8) Screw
- 2	01EL888	2	Support Element Rail, Left Use 46K4284 (2) Screw (no Nut Clip on left rail)
- 3	01EL888	2	Support Element Rail, Right Use 46K4284 (2) Screw, 74F1823 (2) Nut Clip
- 4	01KV745	2	Bracket Use 46K4284 (2) Screw
- 5	01EL599	1	Bracket, Cable Management Use 46K4284 (4) Screw, 74F1823 (4) Nut Clip
- 6	01KU608	1	Bracket, Cable Management Use 46K4284 (4) Screw, 74F1823 (4) Nut Clip

Note: Reuse screw (2) from kit.

Chapter 3. Cable guide

Assembly 19: Power cords

Table 3-1. Power cords

Asm-Index	Part Number	Units	Description
30 amp / 200-208V & 240V AC power cord			
19 -	39M5416	AR	Power Cord, 14ft US , Canada, LA & Japan (1) Phase w/Twist-Lock Plug 30A / 250V NEMA L6-30
-	39M5418	AR	Power Cord: 14ft US , Canada, LA & Japan (1) Phase w/RussellStoll (Water-Tight) Plug 30A / 250V RussellStoll 3750DP
30 amp / 230V AC power cord--EMEA			
-	39M5414	AR	Power Cord: 14ft EMEA (1) Phase w/IEC 309 Plug & "HAR" Bulk Wire 32A / 220-240V IEC 309 Hubbell C332P6W
30 amp / 230V AC power cord--EMEA (LSZH)			
-	01PP883	AR	Power Cord: 14ft EMEA (1) Phase w/IEC 309 Plug & "HAR / Low Smoke Zero Halogen" Bulk Wire 32A / 220-240V IEC 309 Hubbell C332P6W
30 amp / 230V - 240V AC power cord--Australia and New Zealand			
-	39M5419	AR	Power Cord: 14ft Australia & New Zealand (1) Phase w/Plug & "HAR" Bulk Wire 32A / 250V PDL 56P332
30 amp / 220V AC Power Cord--Korea			
-	39M5420	AR	Power Cord: 14ft Korea (1) Phase w/Plug & "HAR" Bulk Wirer 30A / 250V Shinju SJ-P3302

Assembly 20: Cable assemblies

Table 3-2. Cable assemblies

Asm-Index	Part Number	Units	Description
Servers and switches (red)			
20 -	01KU159	AR	Cable assembly: Switch #1 P01 to Switch #2 P01
-	01KU160	AR	Cable assembly: Switch #1 P02 to Switch #2 P02
-	01KU634	AR	Cable assembly: Switch #1 P06 o Switch #2 MGMT Port
-	01KU635	AR	Cable assembly: Switch #1 MGMT Port to Switch #2 P06
-	01EL322	AR	Cable assembly: SE Server #1 (A42) to Switch #1 P05 (IMM)
-	01EL323	AR	Cable assembly: SE Server #1 (A42) to Switch #1 P03
-	01EL324	AR	Cable assembly: SE Server #1 (A42) to Switch #2 P03
-	01EL325	AR	Cable assembly: SE Server #2 (A41) to Switch #2 P05 (IMM)
-	01EL326	AR	Cable assembly: SE Server #2 (A41) to Switch #1 P04

Table 3-2. Cable assemblies (continued)

Asm-Index	Part Number	Units	Description
-	01EL327	AR	Cable assembly: SE Server #2 (A41) to Switch #2 P04
-	01KU636	AR	Cable assembly: Switch #1 P09 to iPDU #1 (ET)
-	01KU637	AR	Cable assembly: Switch #2 P09 to iPDU #2 (ET)
Power (red)			
-	01KU982	AR	Cable assembly: SE Server #1 (A42) PS02 to PDU1-P01
-	01KU983	AR	Cable assembly: SE Server #1 (A42) PS01 to PDU2-P01
-	01KU984	AR	Cable assembly: SE Server #2 (A41) PS02 to PDU1-P02
-	01KU985	AR	Cable assembly: SE Server #2 (A41) PS01 to PDU2-P02
-	01KU776	AR	Cable assembly: Switch #1 (A40) PWR to PDU2-P03
-	02EC037	AR	Cable assembly: Switch #2 (A39) PWR to PDU1-P03
-	01KV439	AR	Cable assembly: KVM Switch-PWR to PDU2 or PDU1-P05
-	39M5377	AR	Cable assembly: 2.8m Display-PWR to PDU1 or PDU2-P04
CPC (red) A09			
-	01EL328	AR	Cable assembly: Switch #1 P11 to LG05-P01 (FSP1)
-	01EL329	AR	Cable assembly: Switch #2 P11 to LG05-P02 (FSP1)
-	01EL330	AR	Cable assembly: Switch #1 P12 to LG06-P01 (FSP2)
-	01EL331	AR	Cable assembly: Switch #2 P12 to LG06-P02 (FSP2)
-	01EL359	AR	Cable assembly: PDU1-P12 to PSU2
-	01EL360	AR	Cable assembly: PDU2-P12 to PSU3
CPC (red), additional PSUs			
-	01EL357	AR	Cable assembly: PDU1-P08 to PSU1
-	01EL358	AR	Cable assembly: PDU2-P08 to PSU4
Drawer 1 - A14			
-	01EL337	AR	Cable assembly: Switch #1 P13 to LG01-P01 (FSP1)
-	01EL338	AR	Cable assembly: Switch #2 P13 to LG01-P02 (FSP1)
-	01EL339	AR	Cable assembly: Switch #1 P14 to LG11-P01 (FSP2)
-	01EL340	AR	Cable assembly: Switch #2 P14 to LG11-P02 (FSP2)
-	01KV965	AR	Cable assembly: PDU1-P06 to PSU1
-	01KV966	AR	Cable assembly: PDU2-P06 to PSU2
Drawer 2 - A01			
-	01PP534	AR	Cable assembly: Switch #1 P10 to iPDU #3 (ET)
-	01PP535	AR	Cable assembly: Switch #2 P10 to iPDU #4 (ET)

Table 3-2. Cable assemblies (continued)

Asm-Index	Part Number	Units	Description
-	01PP634	AR	Cable assembly: Switch #1 P15 to LG01-P01 (FSP1)
-	01PP635	AR	Cable assembly: Switch #2 P15 to LG01-P02 (FSP1)
-	01PP636	AR	Cable assembly: Switch #1 P16 to LG11-P01 (FSP2)
-	01PP637	AR	Cable assembly: Switch #2 P16 to LG11-P02 (FSP2)
-	01PP551	AR	Cable assembly: PDU3-P10 to PSU1
-	01PP552	AR	Cable assembly: PDU4-P10 to PSU2
Drawer 3 - A23			
-	01PP638	AR	Cable assembly: Switch #1 P17 to LG01-P01 (FSP1)
-	01PP639		Cable assembly: Switch #2 P17 to LG01-P02 (FSP1)
-	01PP640	AR	Cable assembly: Switch #1 P18 to LG11-P01 (FSP2)
-	01PP641	AR	Cable assembly: Switch #2 P18 to LG11-P02 (FSP2)
-	01PP553	AR	Cable assembly: PDU3-P06 to PSU1
-	01PP554	AR	Cable assembly: PDU4-P06 to PSU2
Drawer 4 - A31			
-	01PP642	AR	Cable assembly: Switch #1 P19 to LG01-P01 (FSP1)
-	01PP643	AR	Cable assembly: Switch #2 P19 to LG01-P02 (FSP1)
-	01PP644	AR	Cable assembly: Switch #1 P20 to LG11-P01 (FSP2)
-	01PP645	AR	Cable assembly: Switch #2 P20 to LG11-P02 (FSP2)
-	01PP555	AR	Cable assembly: PDU3-P02 to PSU1
-	01PP556	AR	Cable assembly: PDU4-P02 to PSU2
PCIe			
-	01KU219	AR	Cable assembly: 1.0 meter Long, Rev #3 (A01 & A14)
-	01KV405	AR	Cable assembly: 1.5 meter Long, Rev #3 (A23)
-	01KV406	AR	Cable assembly: 2.0 meter Long, Rev #3 (A31)
HMC			
-	01PP718	AR	Cable assembly: Ethernet Cat 5e w/FT-4 (50ft Long)
Ensemble feature			
-	01KU230	AR	Cable assembly: Switch #1 P07 to I/O Card
-	01KU231	AR	Cable assembly: Switch #2 P08 to I/O Card
Field spares			
-	00LU389	AR	Cable assembly: E/Net 1.0 m
-	00LU390	AR	Cable assembly: E/Net 2.0 m
-	00LU391	AR	Cable assembly: E/Net 3.0 m

Table 3-2. Cable assemblies (continued)

Asm-Index	Part Number	Units	Description
-	02EC038	AR	Cable assembly: AC Jumper for PDUs 1.75 m
KVM switch cables and label			
-	01PP046	AR	Cable assembly: KVM Swtich (port #1) to Servers #1 (A42)
-	01PP047	AR	Cable assembly: KVM Swtich (port #2) to Servers #2 (A41)
-	01PP047	AR	Label sheet: Plugging locations for MFG
FTS for Ficon (single-mode)			
-	45D7165	AR	FTS Trunk: 2.0m / 6.6 ft
Power cord label (dual)			
-	01PP708	AR	Label for Power Cord: PDU #1 - PDU #4
Power cord label (Denmark)			
-	45D2199	AR	Label for power cords (Denmark)
Wrap plugs			
-	10N7405	AR	Wrap Plug: 1GB E/Net (Copper)
Wrap plug for ICA-SR (Coupling)			
-	15R7536	AR	Wrap Plug: LC Dual Wrap (Fiber)
Wrap plug for Coupling Express LR (Coupling)			
-	74Y0792	AR	Wrap Plug: 24 pos MTP Wrap (Fiber)
Wrap plug for Coupling Express LR (Coupling)			
-	12R9544	AR	Fiber Optic assembly: SM LC to LC (2.0m)

Appendix. Notices

This information was developed for products and services offered in the US.

IBM may not offer the products, services, or features discussed in this document in other countries. Consult your local IBM representative for information on the products and services currently available in your area. Any reference to an IBM product, program, or service is not intended to state or imply that only that IBM product, program, or service may be used. Any functionally equivalent product, program, or service that does not infringe any IBM intellectual property right may be used instead. However, it is the user's responsibility to evaluate and verify the operation of any non-IBM product, program, or service.

IBM may have patents or pending patent applications covering subject matter described in this document. The furnishing of this document does not grant you any license to these patents. You can send license inquiries, in writing, to:

*IBM Director of Licensing
IBM Corporation
North Castle Drive, MD-NC119
Armonk, NY 10504-1785
US*

INTERNATIONAL BUSINESS MACHINES CORPORATION PROVIDES THIS PUBLICATION "AS IS" WITHOUT WARRANTY OF ANY KIND, EITHER EXPRESS OR IMPLIED, INCLUDING, BUT NOT LIMITED TO, THE IMPLIED WARRANTIES OF NON-INFRINGEMENT, MERCHANTABILITY OR FITNESS FOR A PARTICULAR PURPOSE. Some jurisdictions do not allow disclaimer of express or implied warranties in certain transactions, therefore, this statement may not apply to you.

This information could include technical inaccuracies or typographical errors. Changes are periodically made to the information herein; these changes will be incorporated in new editions of the publication. IBM may make improvements and/or changes in the product(s) and/or the program(s) described in this publication at any time without notice.

Any references in this information to non-IBM websites are provided for convenience only and do not in any manner serve as an endorsement of those websites. The materials at those websites are not part of the materials for this IBM product and use of those websites is at your own risk.

IBM may use or distribute any of the information you provide in any way it believes appropriate without incurring any obligation to you.

Information concerning non-IBM products was obtained from the suppliers of those products, their published announcements or other publicly available sources. IBM has not tested those products and cannot confirm the accuracy of performance, compatibility or any other claims related to non-IBM products. Questions on the capabilities of non-IBM products should be addressed to the suppliers of those products.

Statements regarding IBM's future direction or intent are subject to change or withdrawal without notice, and represent goals and objectives only.

This information contains examples of data and reports used in daily business operations. To illustrate them as completely as possible, the examples include the names of individuals, companies, brands, and products. All of these names are fictitious and any similarity to actual people or business enterprise is entirely coincidental.

Trademarks

IBM, the IBM logo, and [ibm.com](http://www.ibm.com)[®] are trademarks of International Business Machines Corp., registered in many jurisdictions worldwide. Other product and service names might be trademarks of IBM or other companies. A current list of IBM trademarks is available on the web at “Copyright and trademark information” at www.ibm.com/legal/copytrade.shtml.

Linux is a trademark of Linus Torvalds in the United States, other countries, or both.

Microsoft, Windows, Windows NT, and the Windows logo are trademarks of Microsoft Corporation in the United States, other countries, or both.

Class A Notices

The following Class A statements apply to this IBM product. The statement for other IBM products intended for use with this product will appear in their accompanying manuals.

Federal Communications Commission (FCC) Statement

Note: This equipment has been tested and found to comply with the limits for a Class A digital device, pursuant to Part 15 of the FCC Rules. These limits are designed to provide reasonable protection against harmful interference when the equipment is operated in a commercial environment. This equipment generates, uses, and can radiate radio frequency energy and, if not installed and used in accordance with the instruction manual, may cause harmful interference to radio communications. Operation of this equipment in a residential area is likely to cause harmful interference, in which case the user will be required to correct the interference at his own expense.

Properly shielded and grounded cables and connectors must be used in order to meet FCC emission limits. IBM is not responsible for any radio or television interference caused by using other than recommended cables and connectors or by unauthorized changes or modifications to this equipment. Unauthorized changes or modifications could void the user's authority to operate the equipment.

This device complies with Part 15 of the FCC rules. Operation is subject to the following two conditions: (1) this device may not cause harmful interference, and (2) this device must accept any interference received, including interference that may cause undesired operation.

Industry Canada Compliance Statement

This Class A digital apparatus complies with Canadian ICES-003.

Avis de conformité à la réglementation d'Industrie Canada

Cet appareil numérique de la classe A est conforme à la norme NMB-003 du Canada.

European Community Compliance Statement

This product is in conformity with the protection requirements of EU Council Directive 2014/30/EU on the approximation of the laws of the Member States relating to electromagnetic compatibility. IBM cannot accept responsibility for any failure to satisfy the protection requirements resulting from a non-recommended modification of the product, including the fitting of non-IBM option cards.

This product has been tested and found to comply with the limits for Class A Information Technology Equipment according to European Standard EN 55032. The limits for Class A equipment were derived for commercial and industrial environments to provide reasonable protection against interference with licensed communication equipment.

European Community contact:
IBM Deutschland GmbH
Technical Regulations, Department M372
IBM-Allee 1, 71139 Ehningen, Germany
Tele: +49 (0) 800 225 5423 or +49 (0) 180 331 3233
email: halloibm@de.ibm.com

Warning: This is a Class A product. In a domestic environment, this product may cause radio interference, in which case the user may be required to take adequate measures.

VCCI Statement - Japan

この装置は、クラス A 情報技術装置です。この装置を家庭環境で使用すると電波妨害を引き起こすことがあります。この場合には使用者が適切な対策を講ずるよう要求されることがあります。 VCCI-A

The following is a summary of the Japanese VCCI statement above:

This is a Class A product based on the standard of the VCCI Council. If this equipment is used in a domestic environment, radio interference may occur, in which case the user may be required to take corrective actions.

Japan JIS C 61000-3-2 Compliance

(一社) 電子情報技術産業協会 高調波電流抑制対策実施
要領に基づく定格入力電力値： Knowledge Centerの各製品の
仕様ページ参照

For products less than or equal to 20 A per phase, the following statement applies:

高調波電流規格 JIS C 61000-3-2 適合品

For products greater than 20 A, single-phase, the following statements apply:

高調波電流規格 JIS C 61000-3-2 準用品

本装置は、「高圧又は特別高圧で受電する需要家の高調波抑制対策ガイドライン」対象機器（高調波発生機器）です。

回路分類：6（単相、PFC回路付）

換算係数：0

For products greater than 20 A per phase, three-phase, the following statements apply:

高調波電流規格 JIS C 61000-3-2 準用品

本装置は、「高圧又は特別高圧で受電する需要家の高調波抑制対策ガイドライン」対象機器（高調波発生機器）です。

回路分類 : 5 (3相、PFC回路付)

換算係数 : 0

Electromagnetic Interference (EMI) Statement - People's Republic of China

声 明

此为 A 级产品, 在生活环境中, 该产品可能会造成无线电干扰。在这种情况下, 可能需要用户对其干扰采取切实可行的措施。

Declaration: This is a Class A product. In a domestic environment, this product may cause radio interference, in which case the user may need to perform practical action.

Electromagnetic Interference (EMI) Statement - Taiwan

警告使用者:

這是甲類的資訊產品，在居住的環境中使用時，可能會造成射頻干擾，在這種情況下，使用者會被要求採取某些適當的對策。

The following is a summary of the Taiwan EMI statement above:

Warning: This is a Class A product. In a domestic environment, this product may cause radio interference, in which case the user will be required to take adequate measures.

IBM Taiwan Contact Information:

台灣IBM 產品服務聯絡方式：
台灣國際商業機器股份有限公司
台北市松仁路7號3樓
電話：0800-016-888

Electromagnetic Interference (EMI) Statement - Korea

이 기기는 업무용(A급)으로 전자파적합등록을 한 기기이오니 판매자 또는 사용자는 이 점을 주의하시기 바라며, 가정외의 지역에서 사용하는 것을 목적으로 합니다.

Germany Compliance Statement

Deutschsprachiger EU Hinweis: Hinweis für Geräte der Klasse A EU-Richtlinie zur Elektromagnetischen Verträglichkeit

Dieses Produkt entspricht den Schutzanforderungen der EU-Richtlinie 2014/30/EU zur Angleichung der Rechtsvorschriften über die elektromagnetische Verträglichkeit in den EU-Mitgliedsstaaten und hält die Grenzwerte der EN 55032 Klasse A ein.

Um dieses sicherzustellen, sind die Geräte wie in den Handbüchern beschrieben zu installieren und zu betreiben. Des Weiteren dürfen auch nur von der IBM empfohlene Kabel angeschlossen werden. IBM übernimmt keine Verantwortung für die Einhaltung der Schutzanforderungen, wenn das Produkt ohne Zustimmung von IBM verändert bzw. wenn Erweiterungskomponenten von Fremdherstellern ohne Empfehlung von IBM gesteckt/eingebaut werden.

EN 55032 Klasse A Geräte müssen mit folgendem Warnhinweis versehen werden:

"Warnung: Dieses ist eine Einrichtung der Klasse A. Diese Einrichtung kann im Wohnbereich Funk-Störungen verursachen; in diesem Fall kann vom Betreiber verlangt werden, angemessene Maßnahmen zu ergreifen und dafür aufzukommen."

Deutschland: Einhaltung des Gesetzes über die elektromagnetische Verträglichkeit von Geräten

Dieses Produkt entspricht dem "Gesetz über die elektromagnetische Verträglichkeit von Geräten (EMVG)". Dies ist die Umsetzung der EU-Richtlinie 2014/30/EU in der Bundesrepublik Deutschland.

Zulassungsbescheinigung laut dem Deutschen Gesetz über die elektromagnetische Verträglichkeit von Geräten (EMVG) (bzw. der EMC EG Richtlinie 2014/30/EU) für Geräte der Klasse A

Dieses Gerät ist berechtigt, in Übereinstimmung mit dem Deutschen EMVG das EG-Konformitätszeichen - CE - zu führen.

Verantwortlich für die Einhaltung der EMV Vorschriften ist der Hersteller:

International Business Machines Corp.
New Orchard Road
Armonk, New York 10504
Tel: 914-499-1900

Der verantwortliche Ansprechpartner des Herstellers in der EU ist:

IBM Deutschland GmbH
Technical Regulations, Abteilung M372
IBM-Allee 1, 71139 Ehningen, Germany
Tel: +49 (0) 800 225 5423 or +49 (0) 180 331 3233
email: halloibm@de.ibm.com

Generelle Informationen:

Das Gerät erfüllt die Schutzanforderungen nach EN 55024 und EN 55032 Klasse A.

Electromagnetic Interference (EMI) Statement - Russia

ВНИМАНИЕ! Настоящее изделие относится к классу А.
В жилых помещениях оно может создавать радиопомехи, для
снижения которых необходимы дополнительные меры



Printed in USA

GC28-6976-00

